

Suitable to be coupled screw pumps having shaft $\varnothing 32$ mm and flange $\varnothing 111.1$ mm

LA ELMO S.r.l. SI RISERVA IL DIRITTO DI APPORTARE QUALSIASI VARIAZIONE SENZA ALCUN PREAVVISO.

IN ANY MOMENT AND WITHOUT NOTICE ELMO CAN CHANGE MANUFACTURING PROCESS, PERFORMANCE FEATURES.



ELMO

V.le Certosa 8/B - 27100 Pavia Italy
 Tel. ++39 382 529564 - 422372
 Fax. ++39 382 527041
 E-Mail: info@elmoitaly.com

MOTORI IMMERSI PER ASCENSORI IDRAULICI
 SUBMERSIBLE MOTORS FOR HYDRAULIC LIFTS

UNTEROELMOTOREN FUER HYDRAULISCHE AUFZUEGE

MOTEURS IMMERGES DANS L'HUILE POUR ASCENSEURS HIDRAULIQUES

MOTORI TRIFASI THREE PHASE MOTORS DREIPHASEENMOTOREN MOTEURS TRIPHASES



60 Hz
 22TS-U-UST-
 1609-15

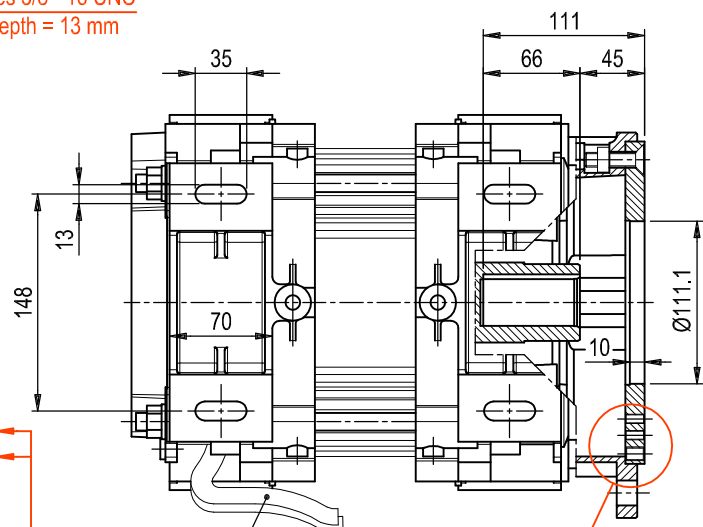
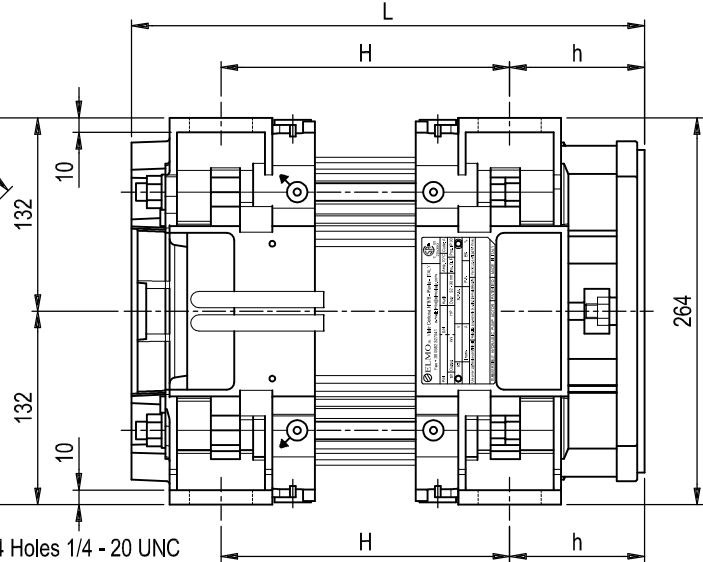
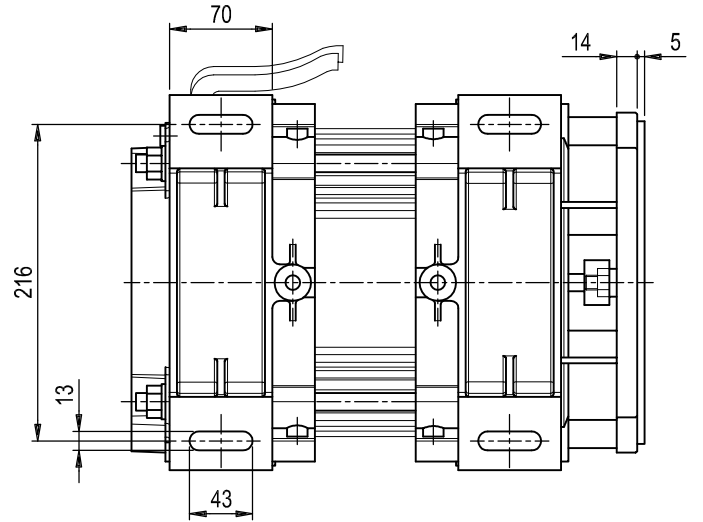
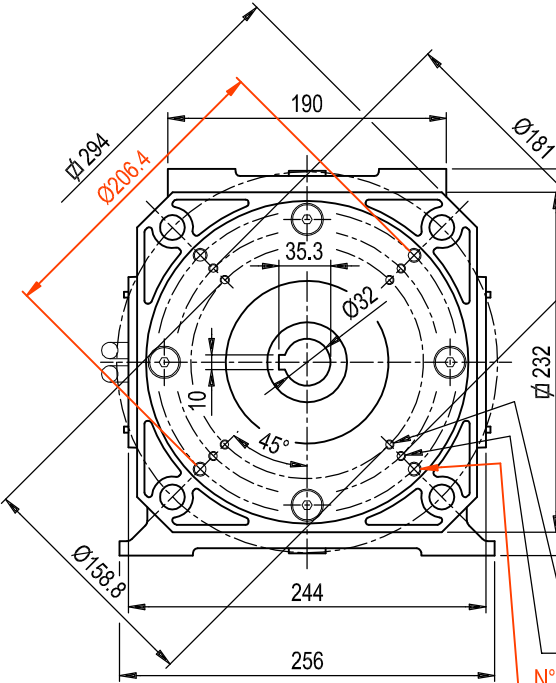
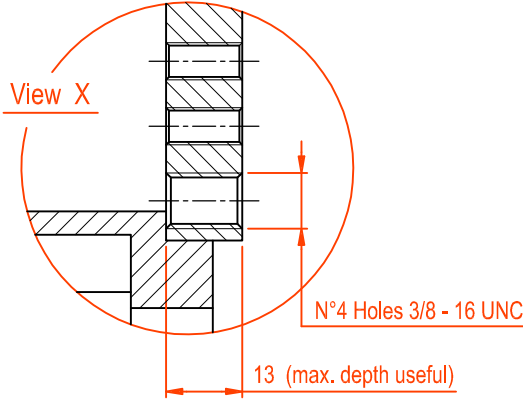

m. 2.20 LUNGH. CAVI ALIMENTAZIONE
 LEADS LENGTH

See View X

THESE MOTORS ARE MADE ONLY ON SPECIFIC REQUEST

MOTORS WITHOUT FLYWHEEL											
COD. BASE - BASIC P/N											
GRANDEZZA - SIZE	POLARITA' - POLARITY	ALIMENTAZ. - POWER SUPPLY	FREQUENZA - FREQUENCY	POTENZA A 60 Hz NOMINAL OUTPUT AT 60 Hz	OMOLOGAZ. TIPO - TYPE APPROVAL	TENSIONE VOLTAGE	SERIE CAVI - CABLE LENGTH	ACCOPPIAMENTO - SUITABLE TO	SENZA VOLANO - WITHOUT FLYWHEEL	PIEDI FISSAGGIO - FIXING FEET	ALTRE QUOTE - OTHER DIMENS.
2	2	T	S	KW	U	V	U	S	7	G	F
DIMENSIONI D'INGOMBRO											POTENZA A 60 Hz NOMINAL OUTPUT AT 60 Hz
OVERALL DIMENSION											HP
L	h	H	HP								
350	92	197	4 0 -								
365		212	5 0 -								
380		227	5 4 -								
400		247	6 0 -								
400		247	6 5 -								
425		272	7 5 -								
425		272	7 7 -								
465		312	9 8 -								
465		362	1 2 5								
570		417	1 4 7								

Nominal output shown with A80 kW is equal to 108 kW